

*Danfoss*



VLT<sup>®</sup> AutomationDrive FC 300

# The new VLT<sup>®</sup> AutomationDrive

redefines the performance of AC drives

- The VLT<sup>®</sup> AutomationDrive represents a single drive concept that controls the entire range of operations from standard to servo on any machine or production line.
- The reliable VLT<sup>®</sup> AutomationDrive intelligently monitors your application and its own performance, and takes action to ensure maximum uptime and trouble free operation before alerting you.
- The modular open-technology platform on which the VLT<sup>®</sup> AutomationDrive is built makes it exceptionally adaptable and programmable.
- Its configurable, user-friendly interface supports local languages and letters.
- With the VLT<sup>®</sup> AutomationDrive series we have intelligent plug-and-play technology and unmatched reliability making drive operation pure child's play.

## Cold plate technology

The drive is built upon a very stable aluminium base integrated with the back panel. This provides high mechanical stability, efficient cooling and the possibility of cold plate operation.

## DC coil

The renowned DC coil is kept to ensure very low harmonic disturbance of the power supply according to IEC-1000-3-2. Compact design: No need for external modules.

## Air guiding screen

A screen to pass cold air by the electronics is easily snapped in place for cold plate cooling.

## Snap off the fan

Like most of the elements, the fan can easily be removed and remounted for easy cleaning.

## Intelligent heat management

Cooling can take place in two ways to offer different sets of benefits:

### Forced convection cooling

- A fan blows cold air through the cooling ribs of the aluminium base to remove heat. The channel is easily cleaned without touching electronics.

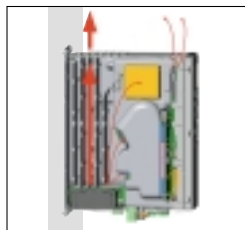

Wall mounted with forced cooling through the heatsink. Ambient air is trickled through the electronics.

### Cold plate cooling

- External cooling is possible through the back side of the aluminium base. An air-guiding screen passes air from the fan past the electronics for additional cooling.

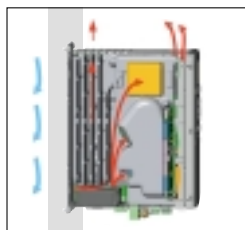

Mounted in a closed cabinet. Clean cabinet air is passed through the electronics. Heat can be removed through the externally cooled heatsink.

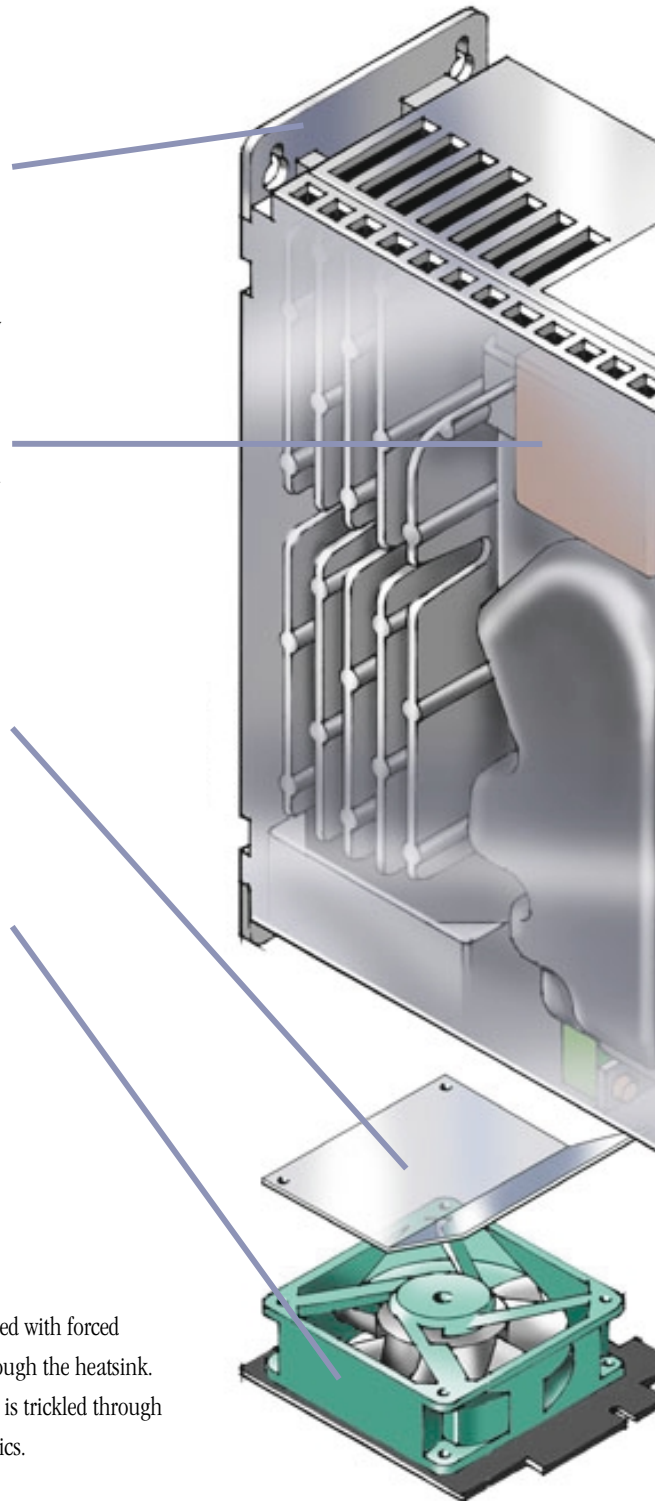

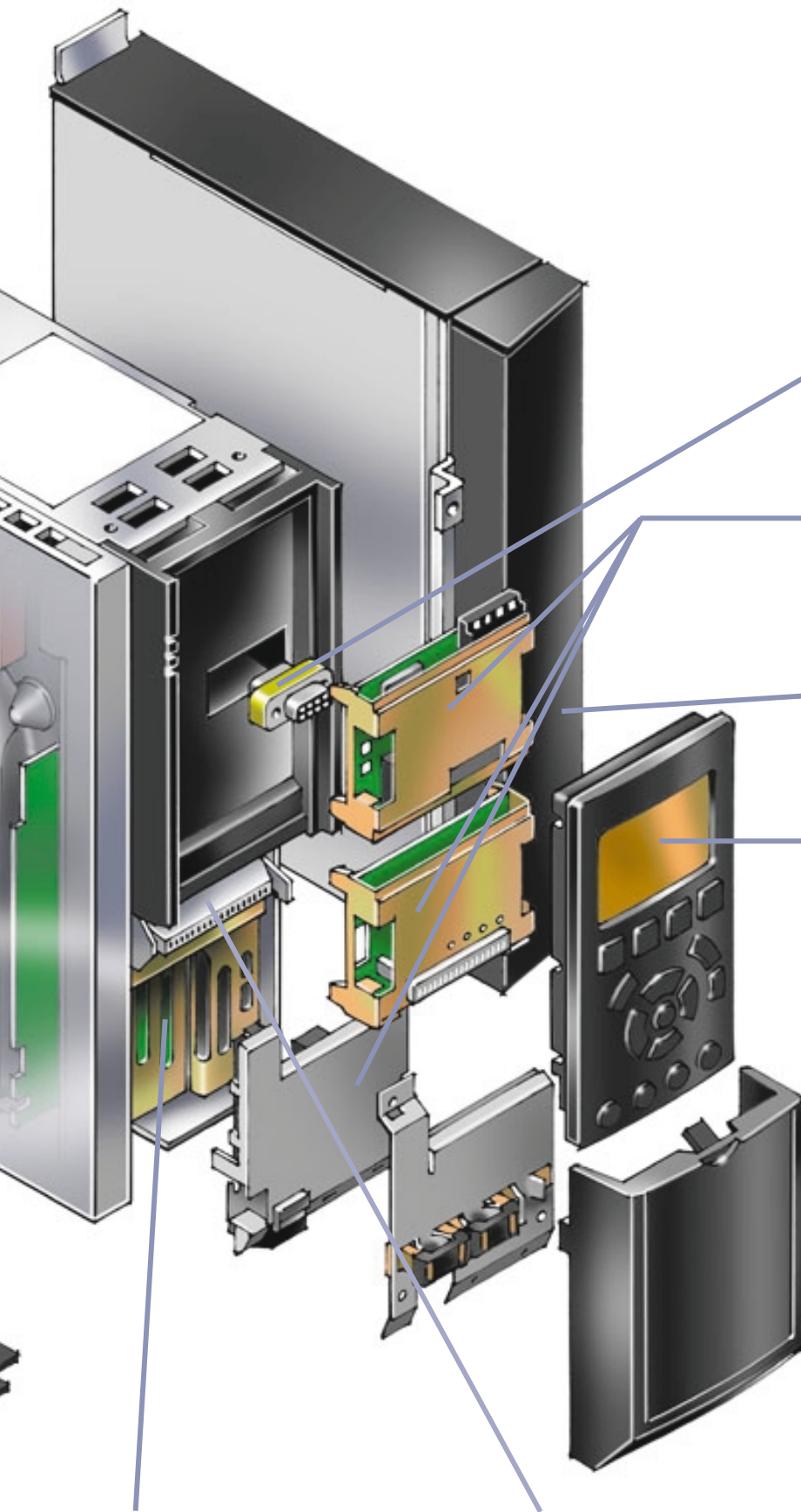

### Hot pluggable LCP

The local control panel (LCP) can be plugged in or out during operation. Settings are easily transferred via the control panel from one drive to another or from a PC with set-up software.

### Options

Options for bus communication, synchronisation, user programs, etc., are delivered ready to plug-and-play. See page 11.

### Free programmable option

Compliant with the open programming platform IEC 61131-3.

### Graphic display

Danfoss Drives renowned removable Local Control Panel has an improved user-interface. Choose between six built-in languages (including Chinese) or have it customised with your own. Two of the languages can be changed by the user. The info button makes the manual virtually redundant.

Users have been involved throughout development to ensure optimum overall functionality of the drive. The user group has significantly influenced design and function of the Local Control Panel. The Automatic Motor Adaptation, the Quick Set-Up menu and the large graphic display make commissioning and operation a breeze.

### Smart logic controller

A Smart Logic Controller built into the standard drives offers a wide range of essential PLC functions, while the optional VLT® Programmable Logic Controller MCO enables complete PLC functionality.

### Safety

The VLT® AutomationDrive comes standard with the safe stop functionality suitable for category 3 installations according to EN 954-1. This feature prevents the drive from starting unintendedly.

### Control signals

Specially developed spring-loaded cage clamps add to reliability and facilitate easy commissioning and service.





*Local control of the VLT® AutomationDrive is done by a local control panel. This is plugged in directly or connected through a cable. The control panel can also be connected directly to a PC for service or commissioning.*

*The VLT® AutomationDrive can be remote commissioned and monitored through a USB plugable cable or bus communication. Special software is available: Wizards, Data transfer tool, VLT® Set-up Software MCT 10 and Language changer.*

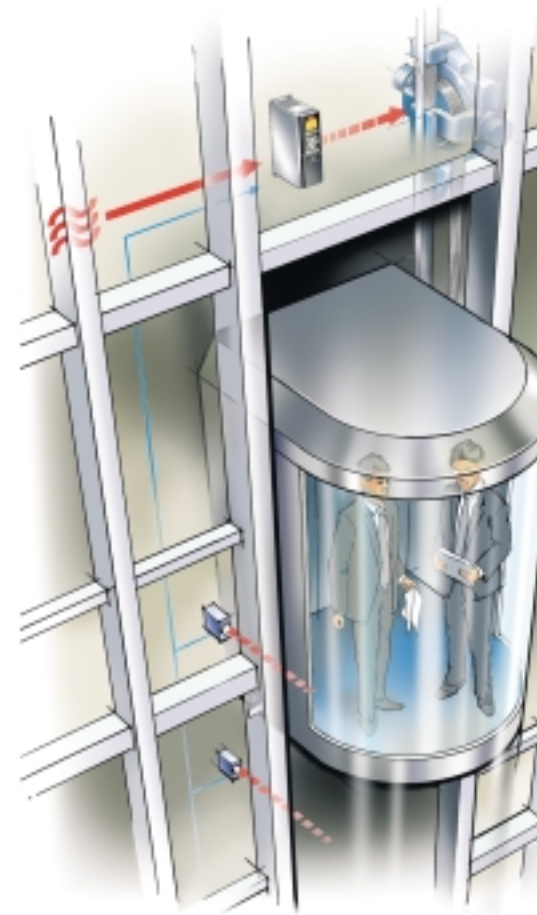

# One drive concept

to run a complete production line

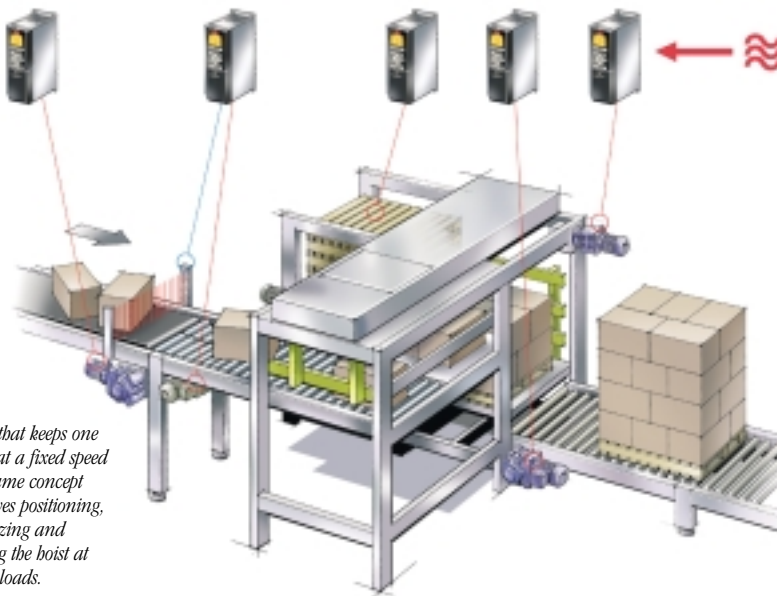

*The drive that keeps one conveyer at a fixed speed is of the same concept as the drives positioning, synchronizing and controlling the boist at changing loads.*

The VLT® AutomationDrive FC 300 represents a single drive concept that controls the entire range of operations from standard to servo on any machine or production line. The standard versions cover a wide range of functions such as essential PLC functionality, automatic fine-tuning of motor control and self-analysis of performance. Positioning, synchronizing, load estimation and even servo performance are covered by the advanced versions. All versions share an identical user interface, so once you have operated one you can operate them all.

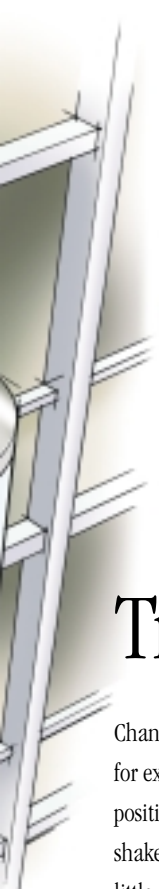

Spring loaded cage clamps are specially designed for the AutomationDrive series. Press, place, release and you have a reliable and stable connection that never needs service attention.

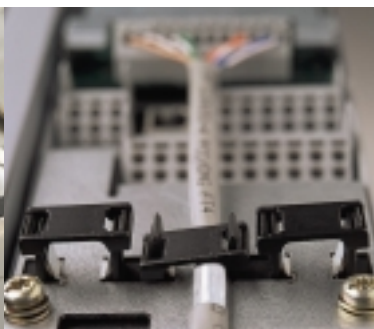

Having mounted the cables in the cage clamps, just press down the black bar over the stripped screen of the cable, and you have a solid and stable installation.

# Treats the crowd as an individual

Changing conditions influence the operation of, for example, an elevator. Depending on the position and the actual load, an elevator tends to shake when stopping or starting – and to stop a little above or below the floor level – because it is calibrated according to an average load.

The VLT® AutomationDrive estimates from the motor/generator currents the actual loads and compensates to make elevators start and stop precisely and smoothly.

These benefits goes for hoist applications as well.

### Benefits:

- Low torque ripple gives passengers a very smooth and comfortable ride.
- Precise load estimation allows for a precise positioning of the car regardless of the load.

# Small loads handled quicker

Your equipment must be dimensioned to handle a maximum load, and traditionally, the speed is determined according to this maximum load.

With the VLT® AutomationDrive you can make use of the installed capacity to automatically speed up operations at a partial or minimum load. The drive estimates the load and maximises the production speed.

### Benefits:

- Load estimation saves time and speeds up production – safely and intelligently.
- Full holding torque capability at 0 RPM gives a smooth ride and reduces the mechanical wear on gears and brakes – less maintenance and more production uptime.

### Gentle to goods – and brakes

When stopped, the VLT® AutomationDrive will slow down the hoist to zero speed before activating the mechanical brake. This causes a gentler handling and almost totally eliminates wear on the brakes.

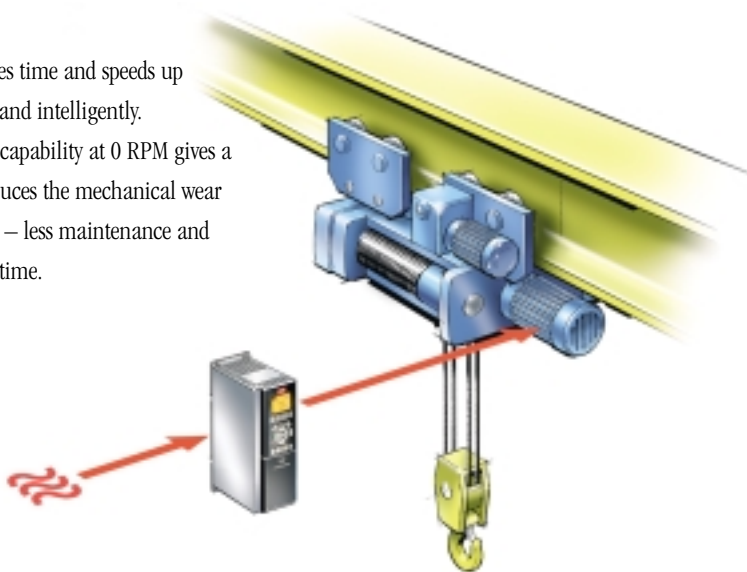

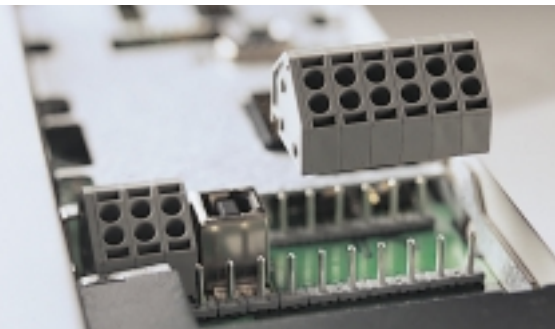

*You don't have to dismount wires in the cage clamps to disconnect the VLT® AutomationDrive. Just unplug the cage clamp instead.*

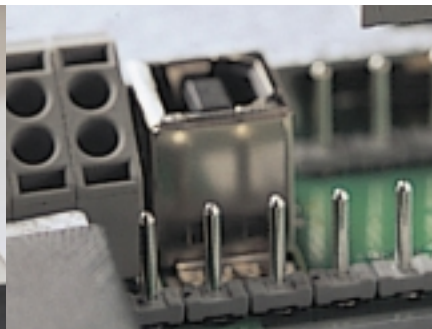

*Use a standard USB cable to connect the VLT® AutomationDrive to your PC.*

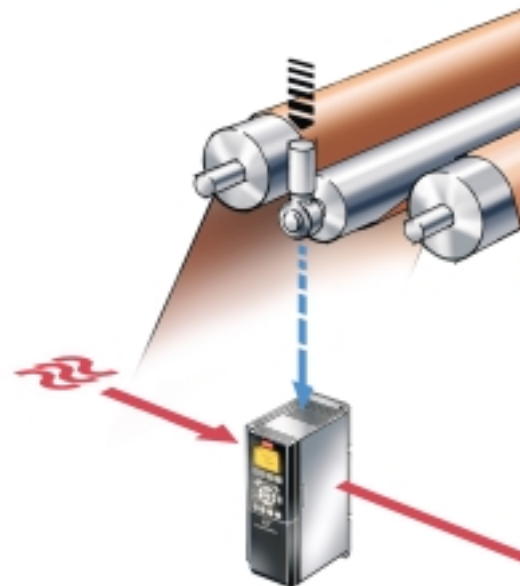

## When torque is the issue

In all winders the torque required to accelerate and decelerate an application varies with the load. With centre winders the required torque even varies with the dimension of the roll. What you need is to operate in torque mode with a high precision torque control.

An example: It is essential in winding operations to fully control the tension of the material to wind. To maintain tangential tension independently of the line speed and roll diameter, the drive must be able to dynamically follow a wide range of torque references.

## The whole production line adapts speed changes

You can change the production speed at any time. Even if the application is made up of several parts. The Precise Pulse Reference feature makes the conveyers follow the encoder from a master conveyer and ensure that all conveyers have the same speed.

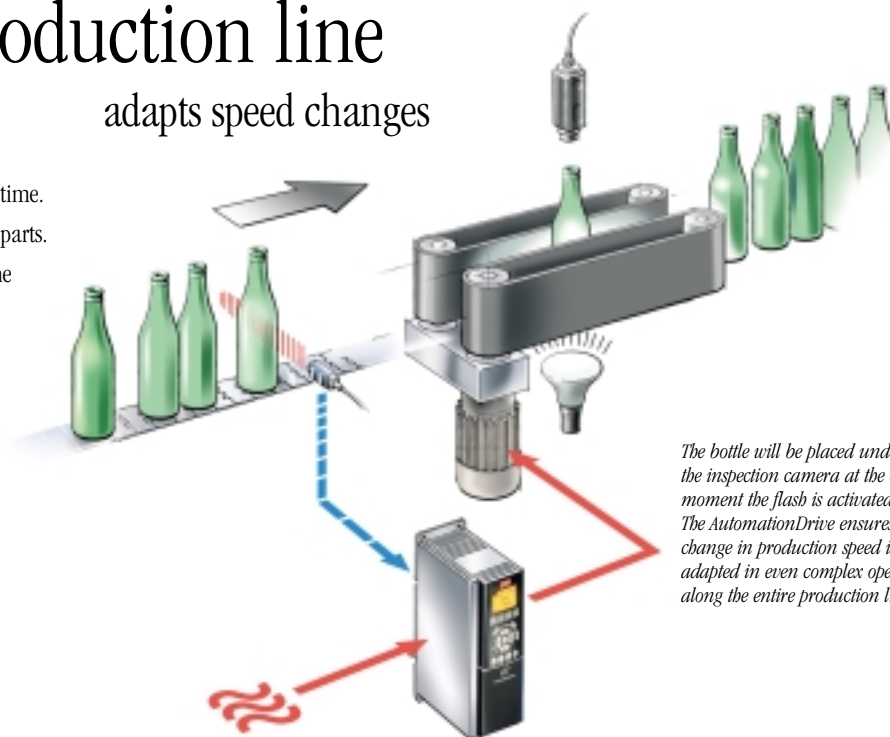

*The bottle will be placed underneath the inspection camera at the exact moment the flash is activated. The AutomationDrive ensures that change in production speed is adapted in even complex operations along the entire production line.*



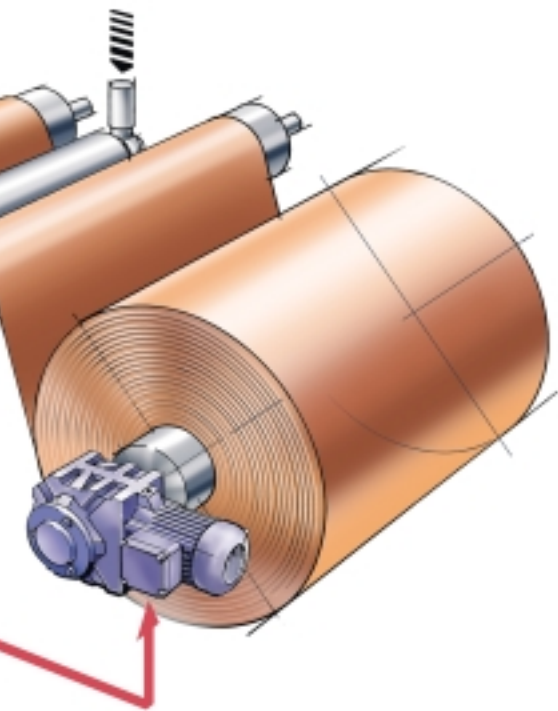

*Plug-and-play is the general approach in the VLT® AutomationDrive. Even power supply, sensor cables and looping connections are gathered in plugs.*



*The bus option ready to plug in underneath the front panel. It can be turned upside down if you prefer the cable to enter from the top.*

## Adds flexibility to precision

The new VLT® AutomationDrive gives you the opportunity to increase or decrease production speed without rebuilding the conveyer. The Precise Pulse Stop feature ensures that products are in precisely the right place on your production line at the right time.

### Benefits:

- You can stop the conveyer at a precise location using only an open loop system independent of production speed.
- The parameter Precise Pulse Stop will compensate the speed of the object when it passes the stop sensor. The result will be a precise stop, regardless of the production speed.

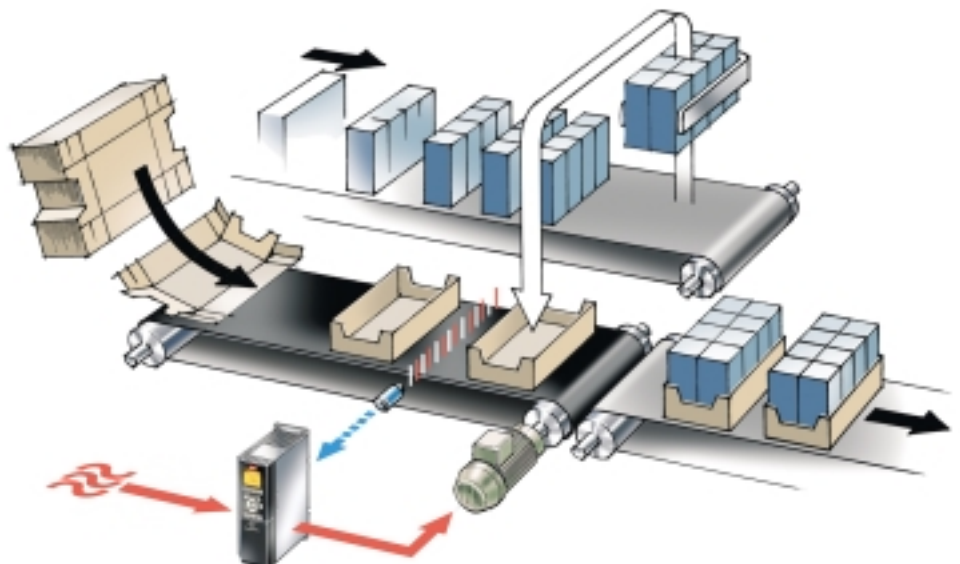

# Users participated in developing the user interface

## Graphical display

- International letters and signs
- Showing bars and graphs
- Easy overview
- 6 different display languages as standard (possibility for local language)

## Other benefits

- Removable during operation
- Up- and download functionality
- IP65 rating when mounted in a panel door

## Illumination

- Selected buttons are now illuminated when active

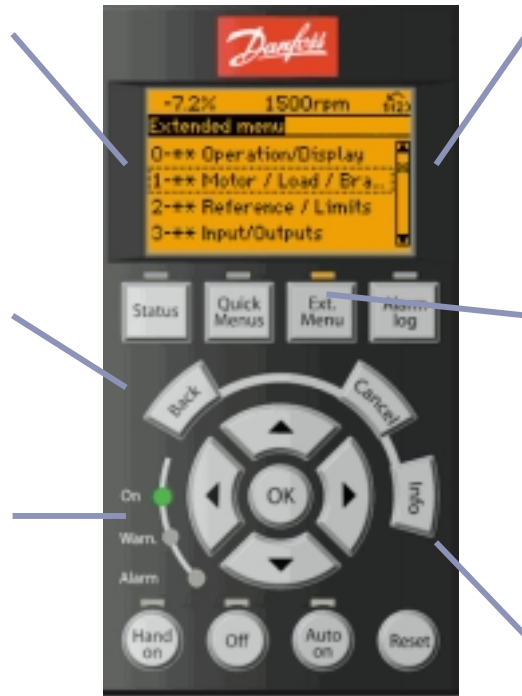

## Menu structure

- Based on the well-known matrix system in today's VLT® drives
- Easy short cut for the experienced user
- Edit and operate in different set-ups simultaneously

## Quick Menu

- A Danfoss defined Quick Menu
- A Personal defined Quick Menu
- A Changes Made Menu lists the parameters unique for your application
- An Application Set-up Menu provides quick and easy setup for specific applications

## New buttons

- Info ("on board manual")
- Cancel ("undo")
- Alarm log (quick access)

## Two performance levels

VLT® AutomationDrive comes in two shaft performance levels. The VLT® AutomationDrive FC 301 ranges from scalar (U/f) to VVC+ and the VLT® AutomationDrive FC 302 ranges from scalar (U/f) to servo performance. The two differs in technical specifications as well as physical size, specified on the pages that follow.

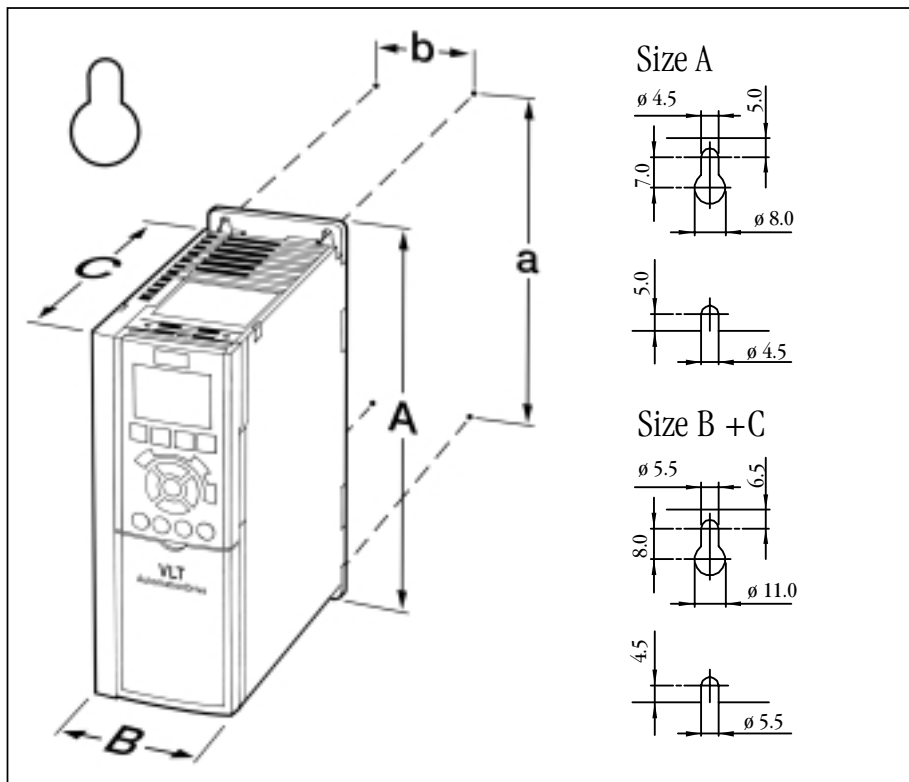

## Mechanical installation

FC 300 allows side-by-side installation. Because of the need for cooling, there must be 10 cm free air passage above and below the FC 300. Drill holes in accordance with the measurements given.

Retighten all four screws.

Fit the decoupling plate to the power cables and the earth screw (Terminal 95).

## Mechanical dimensions (mm)

	Size A	Size B	Size C
<b>Height</b>			
A:	200	268	268
a:	190	257	257
<b>With</b>			
B:	75	90	130
b:	60	70	110
<b>Depth</b>			
C:			
With option A/B	220	220	220
Without options	205	205	205

Frame size A, B og C will depend on electrical data. Se page 10.



# Specifications

## Mains supply (L1, L2, L3):

Supply voltage	200-240 V $\pm$ 10%
Supply voltage	FC 301: 380-480 V / FC 302: 380-500 V $\pm$ 10%
Supply voltage	FC 302: 550-600 V $\pm$ 10%
Supply frequency	50/60 Hz
Displacement Power Factor (cos $\phi$ ) near unity	(> 0.98)
Switching on input supply L1, L2, L3	2 times/min.

## Output data (U, V, W):

Output voltage	0-100% of supply voltage
Output frequency	FC 301: 0.2-132 Hz / FC 302: 0-1000 Hz
Switching on output	Unlimited
Ramp times	0.02-3600 sec.
Closed loop	0-132 Hz

## Digital inputs:

Programmable digital inputs	FC 301: 4(5) / FC 302: 4 (6)
Logic	PNP or NPN
Voltage level	0 - 24 V DC
Voltage level, logic	'0' PNP logic < 5 V DC
Voltage level, logic	'1' PNP logic > 10 V DC
Voltage level, logic	'0' NPN logic > 19 V DC
Voltage level, logic	'1' NPN logic < 14 V DC
Maximum voltage on input	28 V DC
Input resistance, Ri	approx. 4 k $\Omega$

## Analog inputs:

Analog inputs	2
Modes	Voltage or current
Voltage level	FC 301: 0 to +10 V / FC 302: -10 to +10 V (scaleable)
Current level	0/4 to 20 mA (scaleable)
Accuracy of analog inputs	Max. err. 0.5% of full scale
Scan interval	1.0 msec

## Pulse/encoder inputs:

Programmable pulse/encoder inputs	2/1
Voltage level	0 - 24 V DC (PNP positive logic)
Pulse input accuracy (0,1 - 110 kHz)	Max. error: 0.1% of full scale
Encoder input accuracy (1- 110 kHz)	Max. error: 0.05 % of full scale
32(A), 33 (B) and 18 (Z)	

## Digital output:

Programmable digital/pulse outputs	2
Voltage level at digital/frequency output	0 - 24 V DC
Max. output current (sink or source)	40 mA
Maximum output frequency at frequency output	32 kHz
Accuracy on frequency output	Max. error: 0.1% of full scale

## Analog output:

Programmable analog outputs	1
Current range at analog output	0/4 - 20 mA
Max. load to common at analog output	500 $\Omega$
Accuracy on analog output	Max. error: 1% of full scale

## Control card:

Output voltage	10.5 V $\pm$ 0.5 V
Max. load (10 V)	15 mA
Max. load (24 V)	FC 301: 130 mA / FC 302: 200 mA
Scan interval	FC 301: 10 mS / FC 302: 1 mS

## Relay outputs:

Programmable relay outputs	FC 301: 1 / FC 302: 2
Max. terminal load (AC) on 1-3 (break), 1-2 (make), 4-6 (break) power card	240 V AC, 2 A
Max. terminal load (AC) on 4-5 (make) power card	400 V AC, 2 A
Min. terminal load on 1-3 (break), 1-2 (make), 4-6 (break), 4-5 (make) power card	24 V DC 10 mA, 24 V AC 100 mA

## Cable lengths:

Max. motor cable length, screened/armoured	FC 301: 50 m FC 302: 150 m
Max. motor cable length, unscreened/unarmoured	FC 301: 75 m FC 302: 300 m

## Surroundings/ External:

Enclosure	IP 20/IP 55
Enclosure kit available	IP 21/NEMA 1
Vibration test	0.7 g
Max. relative humidity	5% - 95% (IEC 721-3-3; Class 3K3 (non-condensing) during operation)
Aggressive environment (IEC 721-3-3), uncoated class 3C2	
Aggressive environment (IEC 721-3-3), coated class 3C3	
Ambient temperature	Max. 50 °C
(24-hour average)	Max. 45 °C

## Protection and features:

- Electronic thermal motor protection against overload
- Temperature monitoring of the heatsink ensures that the FC 300 cuts out if the temperature reaches 100 °C
- The FC 300 is protected against short-circuits on motor terminals U, V, W
- If a mains phase is missing, the FC 300 will cut out
- The FC 300 is protected against earth fault on motor terminals U, V, W



# Electrical Data

	Current (A)		Apparent Power (kVA)									
	FC 301	FC 302	FC 301		FC 302		FC 302	FC 301		FC 302		FC 302
	200-240V	380-440V	440-480V	380-440V	440-500V	550-600V	200-240V	380-440V	440-480V	380-440V	440-500V	550-600V
Power (kW)												
0.25	1.8	1.8					0.65	0.65				
0.37	2.4	2.4	1.3	1.1	1.3	1.1	0.86	0.86	0.9	0.9	0.9	0.9
0.55	3.5	3.5	1.8	1.6	1.8	1.6	1.26	1.26	1.3	1.3	1.3	1.3
0.75	4.6	4.6	2.4	2.1	2.4	2.1	1.66	1.66	1.7	1.7	1.7	1.7
1.10	6.6	6.6	3.0	3.0	3.0	3.0	2.38	2.38	2.1	2.4	2.1	2.4
1.50	7.5	7.5	4.1	3.4	4.1	3.4	2.70	2.70	2.8	2.7	2.8	2.7
2.20	10.6	10.6	5.6	4.8	5.6	4.8	3.82	3.82	3.9	3.8	3.9	3.8
3.00	12.5	12.5	7.2	6.3	7.2	6.3	4.50	4.50	5.0	5.0	5.0	5.0
3.70	16.7	16.7					6.00	6.00				
4.00			10	8.2	10	8.2	6.4		6.9	6.5	6.9	6.5
5.50			13	11	13	11	9.5		9.0	8.8	9.0	8.8
7.50			16	14.5	16	14.5	11.5		11	11.6	11	11.6

Frame size: **A** **B** **C**

## Example of connections

This diagram shows a typical installation of the AutomationDrive FC 300. Power is connected to the terminals 91 (L1), 92 (L2) and 93 (L3) and the motor is connected to 96 (U), 97 (V) and 98 (W). These numbers also shows on the terminals on the drive. An external DC supply can be connected to terminal 88 and 89.

Analog inputs can be connected to the terminals 53 (V or mA), 54 (V or mA). These gates can be set up to either reference, feedback or termistor. There are 7 digital gates to be connected to the terminals 18, 19, 27, 29, 32, 33 and 37. Two digital input/output terminals (27 and 29) can be set up to show an actual status or warning. The analog output terminal 60 can show process values like for instance  $0 - I_{max}$ . The relay outputs 1 and 2 can be used to control a mechanical brake and to show an actual status or warning. On the terminals 68 (P+) and 69 (N-) RS 485 interface, the drive can be controlled and monitored via serial communication. Cable termination is made easy by toggling the S 801 switch. Switching between PNP or NPN is done simply by setting a parameter.

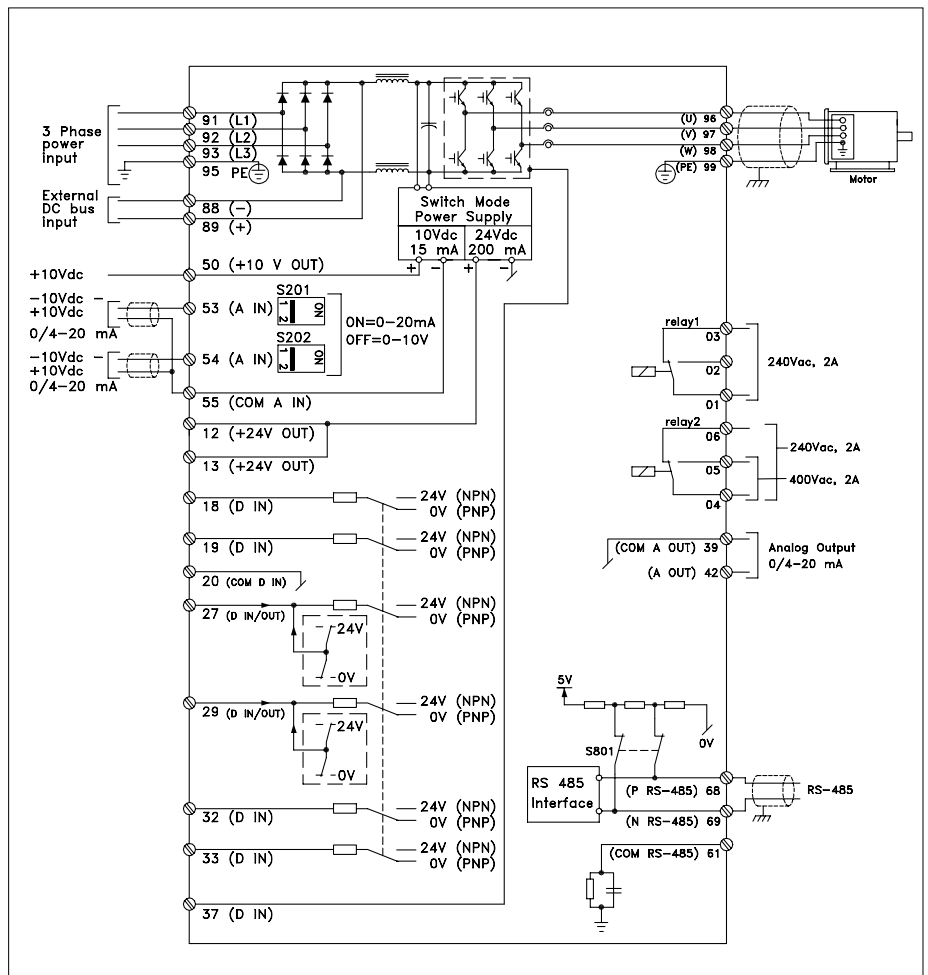

Terminal 37 is suitable for cat. 3 installations according to EN 954-1 (safe stop)

# Choose freely from thousands of configurations

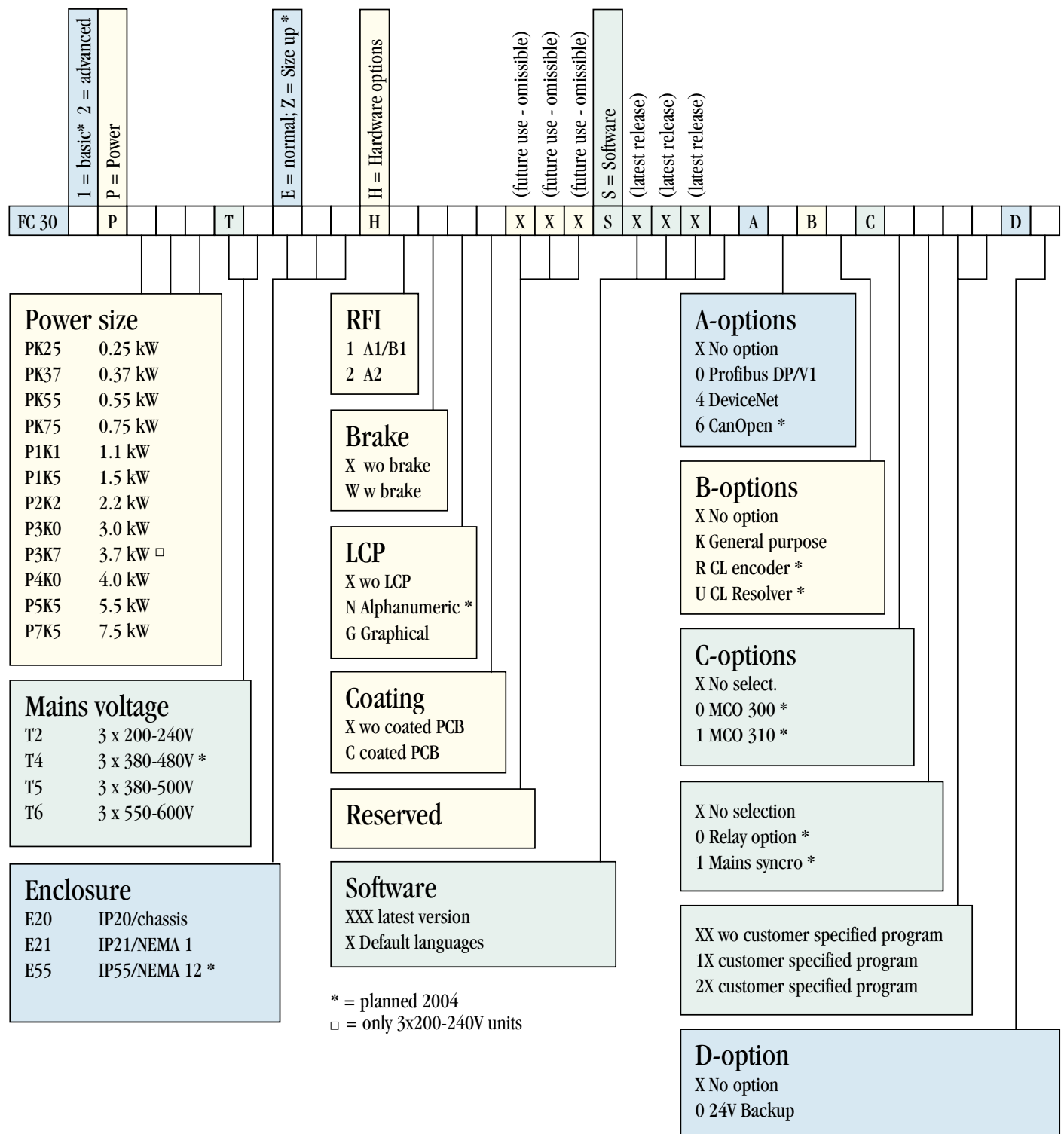

An overview showing the thousands of ways to configure a VLT® AutomationDrive. By choosing between options, you define your unique number of the drive. From this number, your drive is factory built.

You can configure online at [www.danfoss.com/drives](http://www.danfoss.com/drives) – choose "Online Configurator".



VLT® AutomationDrive  
FC300-series



## Constant effort to improve

The focus is clear at Danfoss: as a leading supplier of drives solutions to industry throughout the world, we have spent many years accumulating our technological and application expertise.

Danfoss drives have been produced since 1968 and Danfoss Bauer geared motors since 1927. Today, a long list of references indicates that the name of Danfoss is widely accepted as being synonymous with excellent quality and operational security.

We have focused our professional resources on just one technological area since day one: drives solutions. The years of applying these resources to industrial production lines have given us the opportunity to gather a wealth of experience in industrial applications. The results speak for themselves. Danfoss has enjoyed great success, and we are proud to share it with you.

[www.AutomationDrive.com](http://www.AutomationDrive.com)

---

Danfoss can accept no responsibility for possible errors in catalogues, brochures and other printed material. Danfoss reserves the right to alter its products without notice. This also applies to products already on order provided that such alterations can be made without subsequential changes being necessary in specifications already agreed. All trademarks in this material are property of the respective companies. Danfoss and the Danfoss logotype are trademarks of Danfoss A/S. All rights reserved.

---